

**THE 21st INTERNATIONAL PHYSICS OLYMPIAD - 1990
GRONINGEN, THE NETHERLANDS**

Hans Jordens

Department of Science and Technology, University of Groningen, The Netherlands.

Question 1. X-ray Diffraction from a crystal.

We wish to study X-ray diffraction by a cubic crystal lattice. To do this we start with the diffraction of a plane, monochromatic wave that falls perpendicularly on a 2-dimensional grid that consists of $N_1 \times N_2$ slits with separations d_1 and d_2 . The diffraction pattern is observed on a screen at a distance L from the grid. The screen is parallel to the grid and L is much larger than d_1 and d_2 .

- a - Determine the positions and widths of the principal maximum on the screen.
The width is defined as the distance between the minima on either side of the maxima.

We consider now a cubic crystal, with lattice spacing a and size $N_0 \cdot a \times N_0 \cdot a \times N_1 \cdot a$. N_1 is much smaller than N_0 . The crystal is placed in a parallel X-ray beam along the z -axis at an angle Θ (see Fig. 1). The diffraction pattern is again observed on a screen at a great distance from the crystal.

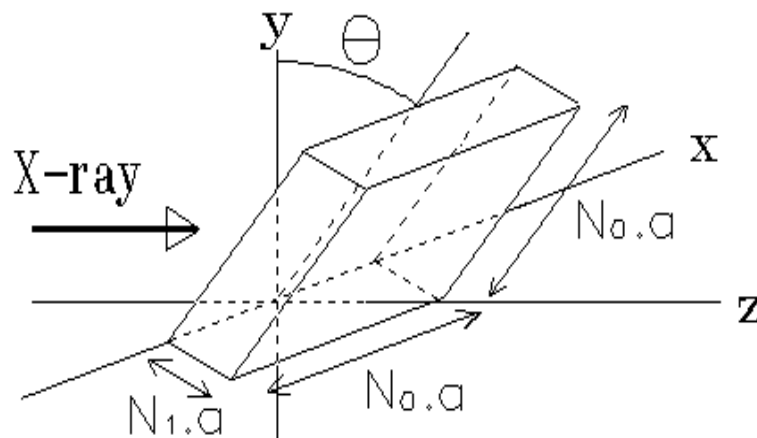

Figure 1 Diffraction of a parallel X-ray beam along the z -axis. The angle between the crystal and the y -axis is Θ .

- b - Calculate the position and width of the maxima as a function of the angle Θ (for small Θ).
- What in particular are the consequences of the fact that $N_1 \ll N_0$.

The diffraction pattern can also be derived by means of Bragg's theory, in which it is assumed that the X-rays are reflected from atomic planes in the lattice. The diffraction pattern then arises from interference of these reflected rays with each other.

- c - Show that this so-called Bragg reflection yields the same conditions for the maxima as those that you found in b.

In some measurements the so-called powder method is employed. A beam of X-rays is scattered by a powder of very many, small crystals. (Of course the sizes of the crystals are much larger than the lattice spacing, a).

Scattering of X-rays of wavelength 0.15 nm by Potassium Chloride [KCl] (which has a cubic lattice, see Fig.2) results in the production of concentric dark circles on a photographic plate. The distance between the crystals and the plate is 0.10 m , and the radius of the smallest circle is 0.053 m (see Fig. 3). K^+ and Cl^- ions have almost the same size, and they may be treated as identical scattering centres.

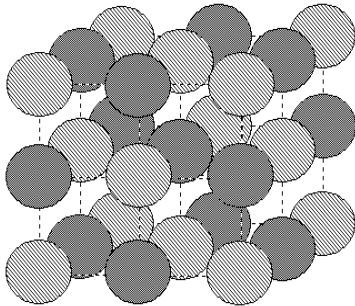

Figure 2. The cubic lattice of Potassium Chloride in which the K^+ and Cl^- ions have almost the same size.

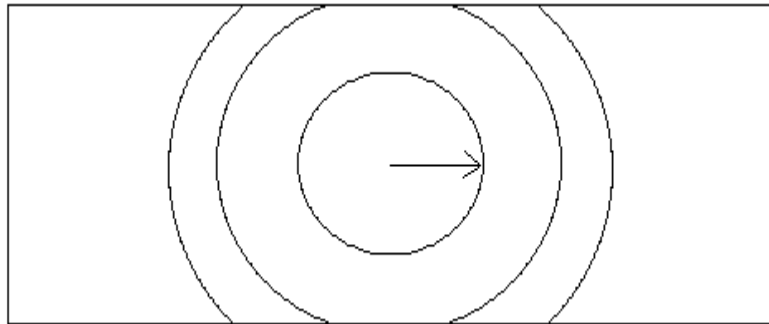

Figure 3. Scattering of X-rays by a powder of KCl crystals results in the production of concentric dark circles on a photographic plate.

d - Calculate the distance between two neighbouring K ions in the crystal.

Question 2. Electric experiments in the magnetosphere of the earth.

In May 1991 the spaceship Atlantis will be placed in orbit around the earth. We shall assume that this orbit will be circular and that it lies in the earth's equatorial plane. At some predetermined moment the spaceship will release a satellite S, which is attached to a conducting rod of length L . We suppose that the rod is rigid, has negligible mass, and is covered by an electrical insulator. We also neglect all friction. Let α be the angle that the rod makes to the line between the Atlantis and the centre of the earth. (see Fig. 1).

S also lies in the equatorial plane.

Assume that the mass of the satellite is much smaller than that of the Atlantis, and that L is much smaller than the radius of the orbit.

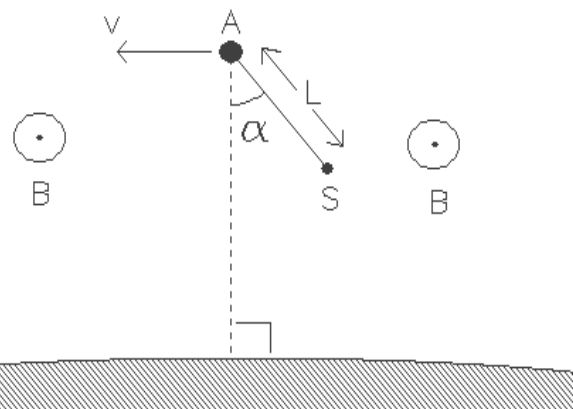

a₁ - Deduce for which value(s) of α the configuration of the spaceship and satellite remain unchanged (with respect to the earth)? In other words, for which value(s) of α is α constant?

Figure 1 The spaceship Atlantis (A) with a satellite (S) in an orbit around the earth. The orbit lies in the earth's equatorial plane. The magnetic field (B) is perpendicular to the diagram and is directed towards the reader.

a₂ - Discuss the stability of the equilibrium for each case.

Suppose that, at a given moment, the rod deviates from the stable configuration by a small angle. The system will begin to swing like a pendulum.

b - Express the period of the swinging in terms of the period of revolution of the system around the earth.

In Fig. 1 the magnetic field of the earth is perpendicular to the diagram and is directed towards the reader. Due to the orbital velocity of the rod, a potential difference arises between its ends. The environment (the magnetosphere) is a rarefied, ionised gas with a very good electrical conductivity. Contact with the ionised gas is made by means of electrodes in A (the Atlantis) and S (the satellite). As a consequence of the motion, a current, I, flows through the rod.

c₁ - In which direction does the current flow through the rod? (Take $\alpha = 0$)

Data:	- the period of the orbit	$T = 5,4 \cdot 10^3 \text{ s}$
	- length of the rod	$L = 2,0 \cdot 10^4 \text{ m}$
	- magnetic field strength of the earth at the height of the satellite	$B = 5,0 \cdot 10^{-5} \text{ Wb.m}^{-2}$
	- the mass of the shuttle Atlantis	$m = 1,0 \cdot 10^5 \text{ kg}$

Next, a current source inside the shuttle is included in the circuit, which maintains a net direct current of 0.1 A in the opposite direction.

c₂ - How long must this current be maintained to change the altitude of the orbit by 10 m.

Assume that α remains zero. Ignore all contributions from currents in the magnetosphere.

- Does the altitude decrease or increase?

Question 3. The rotating neutron star.

A 'millisecond pulsar' is a source of radiation in the universe that emits very short pulses with a period of one to several milliseconds. This radiation is in the radio range of wavelengths; and a suitable radio receiver can be used to detect the separate pulses and thereby to measure the period with great accuracy.

These radio pulses originate from the surface of a particular sort of star, the so-called neutron star. These stars are very compact: they have a mass of the same order of magnitude as that of the sun, but their radius is only a few tens of kilometers. They spin very quickly. Because of the fast rotation, a neutron star is slightly flattened (oblate). Assume the axial cross-section of the surface to be an ellipse with almost equal axes. Let r_p be the polar and r_e the equatorial radii; and let us define the flattening factor by:

$$\epsilon = \frac{(r_e - r_p)}{r_p}$$

Consider a neutron star with a mass of $2.0 \cdot 10^{30}$ kg,
 an average radius of $1.0 \cdot 10^4$ m,
 and a rotation period of $2.0 \cdot 10^{-2}$ s.

a - Calculate the flattening factor, given that the gravitational constant is $6.67 \cdot 10^{-11}$ N.m².kg⁻².

In the long run (over many years) the rotation of the star slows down, due to energy loss, and this leads to a decrease in the flattening. The star has however a solid crust that floats on a liquid interior. The solid crust resists a continuous adjustment to equilibrium shape. Instead, starquakes occur with sudden changes in the shape of the crust towards equilibrium. During and after such a star-quake the angular velocity is observed to change according to figure 1.

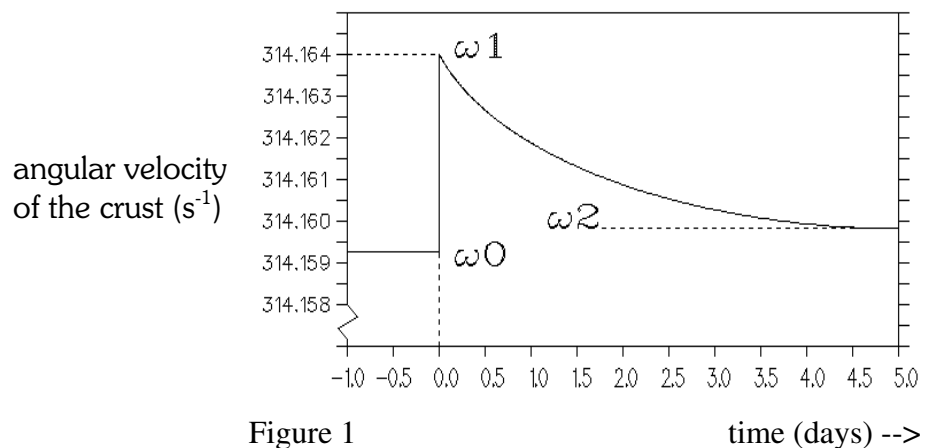

Figure 1 time (days) -->

A sudden change in the shape of the crust of a neutron star results in a sudden change of the angular velocity.

b - Calculate the average radius of the liquid interior, using the data of Fig. 1. Make the approximation that the densities of the crust and the interior are the same. (Ignore the change in shape of the interior).

Question 4. Determination of the efficiency of a LED.

Introduction

In this experiment we shall use two modern semiconductors: the light-emitting diode (LED) and the photo-diode (PD). In a LED, part of the electrical energy is used to excite electrons to higher energy levels. When such an excited electron falls back to a lower energy level, a photon with energy E_{photon} is emitted, where

$$E_{\text{photon}} = \frac{h \cdot c}{\lambda}$$

Here h is Planck's constant, c is the speed of light, and λ is the wavelength of the emitted light. The efficiency of the LED is defined to be the ratio between the radiated power, Φ , and the electrical power used, P_{LED} :

$$\eta = \frac{\Phi}{P_{LED}}$$

In a photo-diode, radiant energy is transformed into electrical energy. When light falls on the sensitive surface of a photo-diode, some (but not all) of the photons free some (but not all) of the electrons from the crystal structure. The ratio between the number of incoming photons per second, N_p , and the number of freed electrons per second, N_e , is called the quantum efficiency, q_p

$$q_p = \frac{N_e}{N_p}$$

The experiment

The purpose of this experiment is to determine the efficiency of a LED as a function of the current that flows through the LED. To do this, we will measure the intensity of the emitted light with a photo-diode. The LED and the PD have been mounted in two boxes, and they are connected to a circuit panel (Fig. 1). By measuring the potential difference across the LED, and across the resistors R_1 and R_3 , one can determine both the potential differences across, and the currents flowing through the LED and the PD.

We use the multimeter to measure VOLTAGES only!! This is done by turning the knob to position 'V'. The meter selects the appropriate sensitivity range automatically. If the display is not on "AUTO" switch "off" and push on "V" again. Connection: "COM" and "V- Ω ".

The box containing the photo-diode and the box containing the LED can be moved freely over the board. If both boxes are positioned opposite to each other, then the LED, the PD and the hole in the box containing the PD remain in a straight line.

Data:- The quantum efficiency of the photo-diode	$q_p = 0.88$
- The detection surface of the PD is	$2.75 \times 2.75 \text{ mm}^2$
- The wave-length of the light emitted from the LED is	635 nm.
- The internal resistance of the voltmeter is:	100 M Ω in the range up to 200 mV 10 M Ω in the other ranges.
	The range is indicated by small numbers on the display.
- Planck's constant	$h = 6.63 \cdot 10^{-34} \text{ J.s}$
- The elementary quantum of charge	$e = 1.6 \cdot 10^{-19} \text{ C}$
- The speed of light in vacuo	$c = 3.00 \cdot 10^8 \text{ m.s}^{-1}$

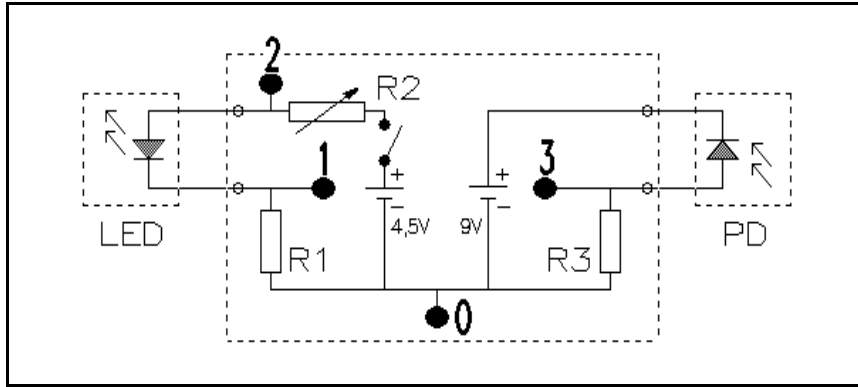

Figure 1.

$$R_1 = 100 \Omega$$

$R_2 =$ variable resistor

$$R_3 = 1 \text{ M}\Omega$$

The points labelled 0, 1, 2 and 3 are measuring points.

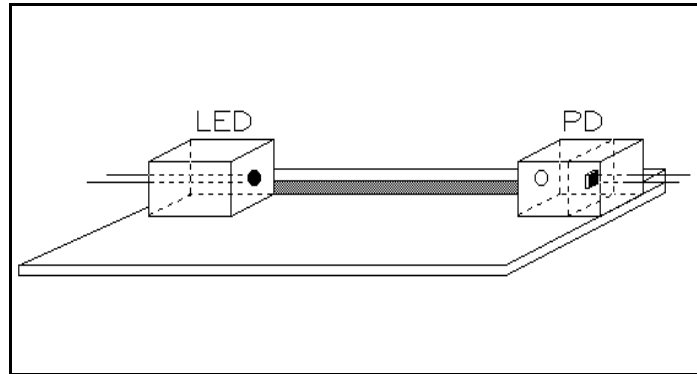

Figure 2 The experimental setup: a board and the two boxes containing the LED and the photo-diode.

Instructions

1. Before we can determine the efficiency of the LED, we must first calibrate the photo-diode. The problem is that we know nothing about the LED.

Show experimentally that the relation between the current flowing through the photo-diode and the intensity of light falling on it, I [$\text{J}\cdot\text{s}^{-1}\cdot\text{m}^{-2}$], is linear.
2. Determine the current for which the LED has maximal efficiency.
3. Carry out an experiment to measure the maximal (absolute) efficiency of the LED.

No marks (points) will be allocated for an error analysis (in THIS experiment only). Please summarize data in tables and graphs with clear indications of quantities (and units).

Question 5. Determination of the ratio of the magnetic field strengths of two different magnets.

Introduction

When a conductor moves in a magnetic field, currents are induced: these are the so-called eddy currents. As a consequence of the interaction between the magnetic field and the induced currents, the moving conductor suffers a reactive force. Thus an aluminium disk that rotates in the neighbourhood of a stationary magnet experiences a braking force.

Material available

1. A stand.
2. A clamp.
3. An homogenous aluminium disk on an axle, in a holder, that can rotate.
4. Two magnets. The geometry of each is the same (up to 1%); each consists of a clip containing two small magnets of identical magnetization and area, the whole producing a homogenous field, B_1 or B_2 .
5. Two weights. One weight has twice the mass (up to 1%) of the other.
6. A stop-watch.
7. A ruler.

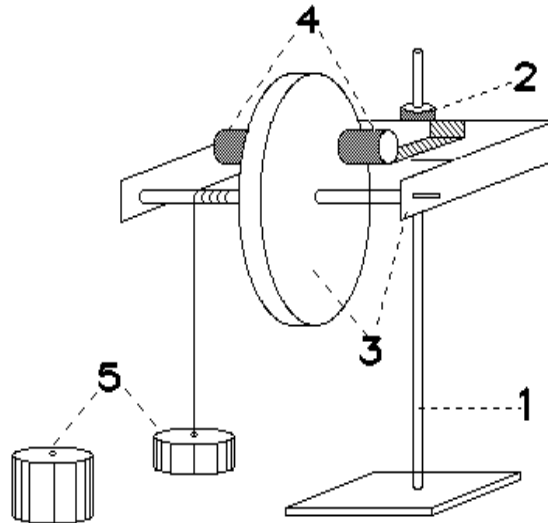

Figure 1.

The experiment

The aluminium disk is fixed to an axle, around which a cord is wrapped. A weight hangs from the cord; and when the weight is released, the disk accelerates until a constant angular velocity is reached. The terminal speed depends, among other things, on the magnitude of the magnetic field strength of the magnet.

Two magnets of different field strengths B_1 or B_2 , are available. Either can be fitted on to the holder that carries the aluminium disk: they may be interchanged.

Instructions

1. Think of an experiment in which the ratio of the magnetic field strengths B_1 and B_2 , of the two magnets can be measured as accurately as possible.
2. Give a - short - theoretical treatment, indicating how one can obtain the ratio from the measurements.
3. Carry out the experiment and determine the ratio.
4. GIVE AN ERROR ESTIMATION.

Use of the stopwatch

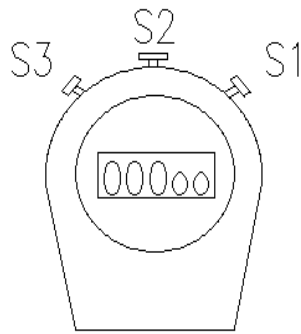

Figure 2.

The stop-watch has three buttons: S_1 , S_2 and S_3 (see Fig. 2).

Button S_2 toggles between the date-time and the stop-watch modes. Switch to the stop-watch mode. One should see this:

00000

On pressing S_1 once, the stop-watch begins timing. To stop it, press S_1 a second time.

The stop-watch can be reset to zero by pressing S_3 once.

Solution of question 1.

- a - Consider first the x-direction. If waves coming from neighbouring slits (with separation d_1) traverse paths of lengths that differ by:

$$\Delta_1 = n_1 \cdot \lambda$$

where n_1 is an integer, then a principal maximum occurs. The position on the screen (in the x-direction) is:

$$x_{n_1} = \frac{n_1 \cdot \lambda \cdot L}{d_1}$$

since $d_1 \ll d_2$.

The path difference between the middle slit and one of the slits at the edge is then:

$$\Delta_{\left(\frac{N_1}{2}\right)} = \frac{N_1}{2} \cdot n_1 \cdot \lambda$$

If on the other hand this path difference is:

$$\Delta_{\left(\frac{N_1}{2}\right)} = \frac{N_1}{2} \cdot n_1 \cdot \lambda + \frac{\lambda}{2}$$

then the first minimum, next to the principal maximum, occurs. The position of this minimum on the screen is given by:

$$x_{n_1} + \Delta x = \frac{\left(\frac{N_1}{2} \cdot n_1 \cdot \lambda + \frac{\lambda}{2}\right) \cdot L}{\frac{N_1}{2} \cdot d_1} = \frac{n_1 \cdot \lambda \cdot L}{d_1} + \frac{\lambda \cdot L}{N_1 \cdot d_1}$$

$$\rightarrow \Delta x = \frac{\lambda \cdot L}{N_1 \cdot d_1}$$

The width of the principal maximum is accordingly:

$$2 \cdot \Delta x = 2 \cdot \frac{\lambda \cdot L}{N_1 \cdot d_1}$$

A similar treatment can be made for the y-direction, in which there are N_2 slits with separation d_2 . The positions and widths of the principal maximal are:

$$(x_{n_1}, y_{n_2}) = \left(\frac{n_1 \cdot \lambda \cdot L}{d_1}, \frac{n_2 \cdot \lambda \cdot L}{d_2}\right)$$

$$2 \cdot \Delta x = 2 \cdot \frac{\lambda \cdot L}{N_1 \cdot d_1} ; \quad 2 \cdot \Delta y = 2 \cdot \frac{\lambda \cdot L}{N_2 \cdot d_2}$$

An alternative method of solution is to calculate the intensity for the 2-dimensional grid as a function of the angle that the beam makes with the screen.

- b - In the x-direction the beam 'sees' a grid with spacing a , so that in this direction we have:

$$x_{n_1} = \frac{n_1 \cdot \lambda \cdot L}{a} \quad \Delta x = 2 \cdot \frac{\lambda \cdot L}{N_0 \cdot a}$$

In the y-direction, the beam 'sees' a grid with effective spacing $a \cdot \cos(\Theta)$. Analogously, we obtain:

$$y_{n_2} = \frac{n_2 \cdot \lambda \cdot L}{a \cdot \cos(\Theta)} \quad \Delta y = 2 \cdot \frac{\lambda \cdot L}{N_0 \cdot a \cdot \cos(\Theta)}$$

In the z-direction, the beam 'sees' a grid with effective spacing $a \cdot \sin(\Theta)$. This gives rise to principal maxima with position and width:

$$y'_{n_3} = \frac{n_3 \cdot \lambda \cdot L}{a \cdot \sin(\Theta)} \quad \Delta y' = 2 \cdot \frac{\lambda \cdot L}{N_1 \cdot a \cdot \sin(\Theta)}$$

This pattern is superimposed on the previous one. Since $\sin(\Theta)$ is very small, only the zeroth-order pattern will be seen, and it is very broad, since $N_1 \cdot \sin(\Theta) \ll N_0$. The diffraction pattern from a plane wave falling on a thin plate of a cubic crystal, at a small angle of incidence to the normal, will be almost identical to that from a two-dimensional grid.

- c - In Bragg reflection, the path difference for constructive interference between neighbouring planes:

$$\Delta = 2 \cdot a \cdot \sin(\phi) \approx 2 \cdot a \cdot \phi = n \cdot \lambda \quad \rightarrow \quad \frac{x}{L} \approx 2 \cdot \phi \approx \frac{n \cdot \lambda}{a} \quad \rightarrow \quad x \approx \frac{n \cdot \lambda \cdot L}{a}$$

Here ϕ is the angle of diffraction.

This is the same condition for a maximum as in section b.

- d - For the distance, $\sqrt{2} \cdot a$, between neighbouring K ions we have:

$$\text{tg}(2\phi) = \frac{x}{L} = \frac{0,053}{0,1} \approx 0,53 \quad \rightarrow \quad a = \frac{\lambda}{2 \cdot \sin(\phi)} \approx \frac{0,15 \cdot 10^{-9}}{2 \cdot 0,24} \approx 0,31 \text{ nm}$$

$$K-K \approx \sqrt{2} \cdot 0,31 \approx 0,44 \text{ nm}$$

Marking Breakdown

- | | | |
|---|------------------------------|----|
| a | position of principal maxima | :1 |
| | width of principal maxima | :3 |
| b | lattice constants | :1 |
| | effect of thickness | :2 |
| c | Bragg reflection | :2 |
| d | Calculation of K-K spacing | :1 |

Solution of question 2.

a_1 - Since $m_2 \ll m_1$, the Atlantis travels around the earth with a constant speed. The motion of the satellite is composed of the circular motion of the Atlantis about the earth and (possibly) a circular motion of the satellite about the Atlantis.

For m_1 we have:

$$m_1 \cdot \Omega^2 \cdot R = \frac{G \cdot m_1 \cdot m_a}{R^2} \rightarrow \Omega^2 = \frac{G \cdot m_a}{R^3}$$

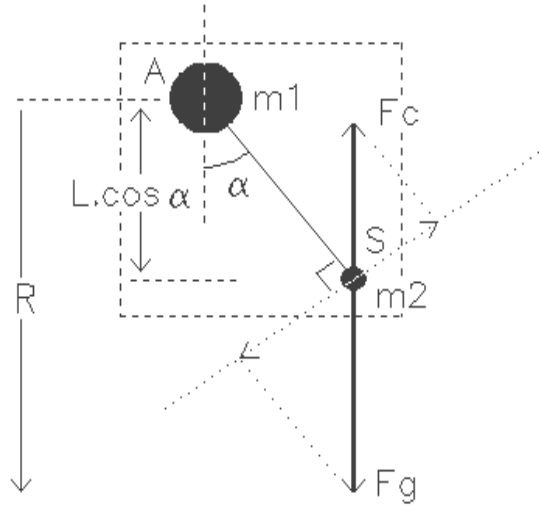

For m_2 we have:

$$m_2 \cdot L \cdot \ddot{\alpha} = -(F_g - F_c) \cdot \sin(\alpha) = -\left(\frac{G \cdot m_2 \cdot m_a}{(R - L \cdot \cos(\alpha))^2} - m_2 \cdot \Omega^2 \cdot (R - L \cdot \cos(\alpha)) \right) \cdot \sin(\alpha)$$

Using the approximation:

$$\frac{1}{(R - L \cdot \cos(\alpha))^2} \approx \frac{1}{R^2} + \frac{2 \cdot L \cdot \cos(\alpha)}{R^3}$$

and equation (1), one finds:

$$L \cdot \ddot{\alpha} = -\left(\frac{G \cdot m_a}{R^2} + \frac{2 \cdot G \cdot m_a}{R^3} \cdot L \cdot \cos(\alpha) - \frac{G \cdot m_a}{R^3} \cdot R + \frac{G \cdot m_a}{R^3} \cdot L \cdot \cos(\alpha) \right) \cdot \sin(\alpha)$$

so:

$$\ddot{\alpha} + 3 \cdot \Omega^2 \cdot \sin(\alpha) \cdot \cos(\alpha) = 0 \quad (2)$$

$$\begin{aligned} \text{If } \alpha \text{ is constant: } \ddot{\alpha} = 0 \quad & \rightarrow \sin(\alpha) = 0 \quad \rightarrow \alpha = 0; \quad \alpha = \pi \\ & \rightarrow \cos(\alpha) = 0 \quad \rightarrow \alpha = \pi/2; \quad \alpha = 3\pi/2 \end{aligned}$$

a₂ - The situation is stable if the moment $M = m_2 L \ddot{\alpha} L = m_2 L^2 \ddot{\alpha}$ changes sign in a manner opposed to that in which the sign of $\alpha - \alpha_0$ changes:

sign($\alpha - \alpha_0$)	-	+	-	+	-	+	-	+	-	+
α	0	$\pi/2$	π	$3\pi/2$	2π					
sign(M)	+	-	-	+	+	-	-	+	+	-
α	0	$\pi/2$	π	$3\pi/2$	2π					

The equilibrium about the angles 0 en π is thus stable, whereas that around $\pi/2$ and $3\pi/2$ is unstable.

b - For small values of α equation (2) becomes:

$$\ddot{\alpha} + 3\Omega^2 \alpha = 0$$

This is the equation of a simple harmonic motion.

The square of the angular frequency is:

$$\omega^2 = 3\Omega^2$$

so:

$$\omega = \Omega \sqrt{3} \quad \rightarrow \quad T_1 = \frac{2\pi}{\omega} = \frac{1}{3} \sqrt{3} \left(\frac{2\pi}{\Omega} \right) \approx 0,58 T_0$$

c₁ - According to Lenz's law, there will be a current from the satellite (S) towards the shuttle (A).

c₂ - For the total energy of the system we have:

$$U = U_{kin} + U_{pot} = \frac{1}{2} m \Omega^2 R^2 - \frac{G m m_a}{R} = -\frac{1}{2} \frac{G m m_a}{R}$$

A small change in the radius of the orbit corresponds to a change in the energy of:

$$\Delta U = \frac{1}{2} \frac{G m m_a}{R^2} \Delta R = \frac{1}{2} m \Omega^2 R \Delta R$$

In the situation under c₁ energy is absorbed from the system as a consequence of which the radius of the orbit will decrease.

Is a current source inside the shuttle included in the circuit, which maintains a net current in the opposite direction, energy is absorbed by the system as a consequence of which the radius of the orbit will increase.

From the assumptions in c₂ we have:

$$\Delta U = F_i v t = B I L \Omega R t = \frac{1}{2} m \Omega^2 R \Delta R \quad \rightarrow \quad t = \frac{1}{2} \frac{m \Omega \Delta R}{B I L}$$

Numerical application gives for the time: $t \approx 5,8 \cdot 10^3$ s; which is about the period of the system.

Marking breakdown:

a ₁	: 1
a ₂	: 1
b - Atlantis in uniform circular motion	: 0,5
- calculation of the period Ω	: 0,5
- equation of motion of the satellite	: 2,5
- equation of motion for small angles	: 0,5
- period of oscillations	: 1
c ₁ -	: 1
c ₂ - calculation of the time the current has to be maintained	: 1,5
- increase or decrease of the radius of the orbit	: 0,5

Solution of question 3.

a - 1st method

For equilibrium we have $F_c = F_g + N$
 where N is normal to the surface.

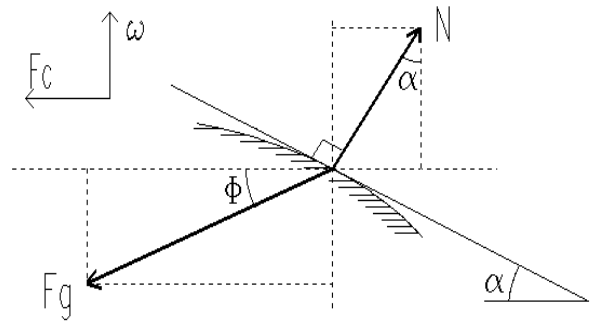

Resolving into horizontal and vertical components, we find:

$$F_g \cdot \cos(\phi) = F_c + N \cdot \sin(\alpha)$$

$$F_g \cdot \sin(\phi) = N \cdot \cos(\alpha) \quad \rightarrow \quad F_g \cdot \cos(\phi) = F_c + F_g \cdot \sin(\phi) \cdot \tan(\alpha)$$

From:

$$F_g = \frac{G \cdot M}{r^2}, \quad F_c = \omega^2 \cdot r, \quad x = r \cdot \cos(\phi), \quad y = r \cdot \sin(\phi) \quad \text{en} \quad \tan(\alpha) = \frac{dy}{dx}$$

we find:

$$y \cdot dy + \left(1 - \frac{\omega^2 \cdot r^3}{G \cdot M} \right) \cdot x \cdot dx = 0$$

where:

$$\frac{\omega^2 \cdot r^3}{G \cdot M} \approx 7 \cdot 10^{-4}$$

This means that, although r depends on x and y, the change in the factor in front of xdx is so slight that we can take it to be constant. The solution of Eq. (1) is then an ellipse:

$$\frac{x^2}{r_e^2} + \frac{y^2}{r_p^2} = 1 \rightarrow \frac{r_p}{r_e} = \sqrt{1 - \frac{\omega^2 \cdot r^3}{G \cdot M}} \approx 1 - \frac{\omega^2 \cdot r^3}{2 \cdot G \cdot M}$$

and from this it follows that:

$$\epsilon = \frac{r_e - r_p}{r_e} = \frac{\omega^2 \cdot r^3}{2 \cdot G \cdot M} \approx 3,7 \cdot 10^{-4}$$

2nd method

For a point mass of 1 kg on the surface,

$$U_{pot} = -\frac{G \cdot M}{r} \quad U_{kin} = \frac{1}{2} \cdot \omega^2 \cdot r^2 \cdot \cos^2(\phi)$$

The form of the surface is such that $U_{pot} - U_{kin} = \text{constant}$. For the equator ($\Phi = 0$, $r = r_e$) and for the pole ($\Phi = \pi/2$, $r = r_p$) we have:

$$\frac{G \cdot M}{r_p} = \frac{G \cdot M}{r_e} + \frac{1}{2} \cdot \omega^2 \cdot r_e^2 \rightarrow \frac{r_e}{r_p} = 1 + \frac{\omega^2 \cdot r_e^3}{2 \cdot G \cdot M}$$

Thus:

$$\epsilon = \frac{r_e - r_p}{r_e} = \frac{1 + \frac{\omega^2 \cdot r_e^3}{2 \cdot G \cdot M} - 1}{1 + \frac{\omega^2 \cdot r_e^3}{2 \cdot G \cdot M}} \approx \frac{\omega^2 \cdot r_e^3}{2 \cdot G \cdot M} \approx 3,7 \cdot 10^{-4}$$

- b - As a consequence of the star-quake, the moment of inertia of the crust I_m decreases by ΔI_m .

From the conservation of angular momentum, we have:

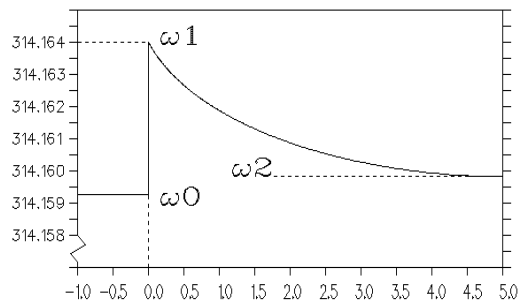

$$I_m \cdot \omega_0 = (I_m - \Delta I_m) \cdot \omega_1 \rightarrow \Delta I_m = I_m \cdot \frac{\omega_1 - \omega_0}{\omega_1}$$

After the internal friction has equalized the angular velocities of the crust and the core, we have:

$$(I_m + I_c) \cdot \omega_0 = (I_m + I_c - \Delta I_m) \cdot \omega_2 \rightarrow \Delta I_m = (I_m + I_c) \cdot \frac{\omega_2 - \omega_0}{\omega_2}$$

$$\frac{I_m}{I_m + I_c} = \frac{(\omega_2 - \omega_0) \cdot \omega_1}{(\omega_1 - \omega_0) \cdot \omega_2} \rightarrow 1 - \frac{I_c}{I_m + I_c} = \frac{(\omega_2 - \omega_0) \cdot \omega_1}{(\omega_1 - \omega_0) \cdot \omega_2}$$

$I (\cdot) R^2$

$$\rightarrow \frac{I_c}{I_m + I_c} = \frac{r_c^2}{r^2} \rightarrow \frac{r_c}{r} = \sqrt{1 - \frac{(\omega_2 - \omega_0) \cdot \omega_1}{(\omega_1 - \omega_0) \cdot \omega_2}} \approx 0.95$$

Marking breakdown

- | | | | |
|---|------------|-------------------------------------------------------|------|
| a | 1st method | - expressions for the forces | :1 |
| | | - equation for the surface | :2 |
| | | - equation of ellipse | :1 |
| | | - flattening factor | :1 |
| | 2nd method | - energy equation | :4 |
| | | - flattening factor | :1 |
| b | | - conservation of angular momentum for crust | :1.5 |
| | | - conservation of angular momentum for crust and core | :1.5 |
| | | - moment of inertia for a sphere | :1 |
| | | - ratio r_c/r | :1 |

Solution of question 4.

1. The linearity of the photo-diode.

The linearity of the photo-diode can be checked by using the inverse square law between distance and intensity. Suppose that the measured distance between the LED and the (box containing the) PD is x . The intensity of the light falling on the PD satisfies:

$$I(x) = \frac{I_0}{x^2}$$

If the intensity is indeed proportional to the current flowing through the PD, it will also be proportional to the voltage, $V(x)$, measured across the resistor R_3 . From (1) it then follows that:

$$\frac{1}{\sqrt{V(x)}} \propto x$$

To obtain the correct value of $V(x)$, one should subtract from the measured voltage V_1 the voltage V_2 that one measures when the LED is turned off (but the LED box is still in place in front of the PD).

x (cm)	V_1 (V)	V_2 (V)	i_1 (μA)	i_2 (μA)	$1/[i_1(x) - i_2(x)]^{1/2}$ ($\mu\text{A}^{-1/2}$)
1.0	5.66	.003	6.23	.003	0.40
2.0	4.07	.004	4.48	.005	0.47
3.0	3.03	.005	3.33	.005	0.55
4.0	2.32	.006	2.55	.006	0.63
5.0	1.83	.006	2.01	.006	0.71
6.0	1.48	.007	1.63	.007	0.79
7.0	1.23	.007	1.35	.007	0.86
8.0	1.006	.008	1.107	.008	0.95
9.0	0.859	.009	0.945	.009	1.03
10.0	0.744	.009	0.818	.009	1.11
11.0	0.648	.010	0.713	.010	1.19
12.0	0.570	.011	0.627	.011	1.27
13.0	0.507	.012	0.558	.012	1.35
14.0	0.456	.012	0.502	.012	1.43
15.0	0.414	.013	0.455	.013	1.50
16.0	0.373	.013	0.410	.014	1.59
17.0	0.341	.014	0.375	.014	1.66
18.0	0.312	.014	0.343	.014	1.74
19.0	0.291	.015	0.320	.015	1.81
20.0	0.272	.015	0.299	.015	1.88

Plotted on a graph, one finds a perfect straight line.

2. The light intensity as a function of the electrical power of the LED

The photo-current i_{PD} is determined from the voltage V over $R_3 = 1M\Omega$. The meter itself has an internal resistance of $100 M\Omega$ in the $200 mV$ range and $10 M\Omega$ in the other ranges. We have then: $i_{PD} = 1.01 V$ resp. $i_{PD} = 1.1 V$ where V is in volts and i_{PD} in μA . The current in ampères through the LED is the voltage over R_1 in volts, divided by 100 .

----- PD -----		----- LED -----				
[x = 5 cm]						
V_1 (V)	V_2 (V)	$i_1 - i_2$ (μA)	i_{LED} (10^{-2} A)	V_{LED} (V)	P_{LED} (10^{-2} W)	$(i_1 - i_2)/P_{LED}$
1.806	.0061	1.98	2.70	1.752	4.73	0.419
1.637	.0061	1.79	2.30	1.742	4.01	0.446
1.511	.0061	1.66	2.08	1.735	3.61	0.460
1.225	.0061	1.34	1.606	1.722	2.77	0.484
1.117	.0061	1.22	1.433	1.718	2.46	0.496
0.903	.0061	0.99	1.123	1.705	1.91	0.518
0.711	.0061	0.78	0.889	1.708	1.52	0.513
0.448	.0061	0.49	0.555	1.673	0.93	0.527
0.315	.0061	0.34	0.410	1.659	0.68	0.5
0.192	.0061	0.21	0.258	1.637	0.42	0.2

The efficiency is proportional to $(i_1 - i_2)/P_{LED}$. In the graph of $(i_1 - i_2)/P_{LED}$ against i_{LED} the maximal efficiency corresponds to $i_{LED} = 0,6 \cdot 10^{-2}$ A. (See figure 2.)

3. Determination of the maximal efficiency.

The LED emits a conical beam with cylindrical symmetry. Suppose we measure the light intensity with a PD of sensitive area d^2 at a distance r_i from the axis of symmetry. Let the intensity of the light there be $\Phi(r_i)$, then we have:

$$i(r_i) = N_e \cdot e = N_f q_f e = \frac{\Phi(r_i)}{h \cdot \nu} \cdot q_f e$$

$$\Phi = \sum_i \Phi(r_i) \cdot \frac{2 \cdot \pi \cdot r_i \cdot d}{d^2} = \frac{2 \cdot \pi}{d} \cdot \sum_i \Phi(r_i) \cdot r_i = \frac{2 \cdot \pi}{d} \cdot \frac{h \cdot \nu}{q_f e} \cdot \sum_i i(r_i) \cdot r_i$$

r_i (mm)	V_1 (V)	V_2 (V)	$(i_1 - i_2) \cdot r_i$ ($\times 10^{-9}$ Am)	r_i (mm)	V_1 (V)	V_2 (V)	$(i_1 - i_2) \cdot r_i$ ($\times 10^{-9}$ Am)
0	1.833	0.006	0	39	0.097	0.006	
3	1.906	0.006	6.27	42	0.089	0.006	4.16
6	1.846	0.006	12.54	45	0.082	0.006	3.86
9	1.750	0.006	17.28	48	0.071	0.006	3.79
12	1.347	0.006	17.76	51	0.066	0.006	3.48
15	0.997	0.006	16.20	54	0.050	0.006	3.39
18	0.643	0.006	12.60	57	0.045	0.006	2.52
21	0.313	0.006	7.14	60	0.037	0.006	2.45
24	0.343	0.006	8.88	63	0.032	0.006	2.08
27	0.637	0.006	18.90	66	0.023	0.006	1.83
30	0.681	0.006	22.20	69	0.017	0.006	1.27
33	0.266	0.006	9.57	72	0.014	0.006	0.88
36	0.119	0.006	4.48	75	0.011	0.006	0.68
							0.49

The efficiency = $\Phi/P_{LED} \approx 0.001$

Marking breakdown

1 linearity of the PD

- inverse square law :1.5
- number of measuring points [1,3>; [3,5>; [5,..> :0.5/1.0/1.5
- dark current :0.5
- correct graph :1

2 determination of current at maximal efficiency

- principle :0.5
- number of measuring points [1,3>; [3,5>; [5,..> :0.5/1.0/1.5
- graph efficiency-current :0.5
- determination of current at maximal efficiency :0.5

3 determination of the maximal efficiency

- determination of the emitted light intensity :1.5
 - via estimation of the cone cross-section :0.5
 - via measurement of the intensity distribution :1.5
- determination of the maximum efficiency :1

Solution of question 5.

1. Theory	Let	- the moment of inertia of the disk be	: I
		- the mass of the weight	: m
		- the moment of the frictional force	: M_f
		- magnetic field strength	: B
		- the radius of the axle	: r
		- the moment of the magnetic force	: M_B

For the motion of the rotating disk we have:

$$I.\alpha = (m.g - m.a).r - M_f - M_B$$

We suppose that M_f is constant but not negligible. Because the disk moves in the magnetic field, eddy currents are set up in the disk. The magnitude of these currents is proportional to B and to the angular velocity. The Lorentz force as a result of the eddy currents and the magnetic field is thus proportional to the square of B and to the angular velocity, i.e.

$$M_B = c.B^2.\omega$$

Substituting this into Eq. (1), we find:

$$I.\alpha = (m.g - m.a).r - M_f - c.B^2.\omega$$

$$v_e = \left(\frac{g.r^2}{c.B^2}\right) \left(m - \frac{M_f}{g.r}\right)$$

After some time, the disk will reach its final constant angular velocity; the angular acceleration is now zero and for the final velocity v_e we find:

The final constant velocity is thus a linear function of m.

2. The experiment

The final constant speed is determined by measuring the time taken to fall the last 21 cm [this is the width of a sheet of paper].

In the first place it is necessary to check that the final speed has been reached. This is done by allowing the weight to fall over different heights. It is clear that, with the weaker magnet, the necessary height before the constant speed is attained will be larger.

Measurements for the weak magnet system:

----- time taken to fall -----

height (m)	smaller weight	larger weight
0.30	5.04 ± 0.02 (s)	2.00 ± 0.01 (s)
0.40	4.67 ± 0.04 (s)	1.71 ± 0.02 (s)
0.50	4.59 ± 0.05 (s)	1.55 ± 0.02 (s)
0.60	4.44 ± 0.06 (s)	1.48 ± 0.01 (s)
0.70	4.49 ± 0.05 (s)	1.44 ± 0.04 (s)
0.80	4.43 ± 0.03 (s)	1.38 ± 0.03 (s)
0.90	4.43 ± 0.04 (s)	1.35 ± 0.02 (s)
1.10	---	1.34 ± 0.05 (s)
1.30	---	1.33 ± 0.04 (s)

3. Final constant speed measurements for both magnet systems and for several choices of weight.

Measurements for the weak magnet:

weight	T (s)	T (s)	T (s)	T (s)	<T> (s)	<v> (m/s)
small	4.42	4.23	4.24	4.33	4.31 ± 0.09	4.9 ± 0.1
large	1.89	1.91	1.98	1.92	1.93 ± 0.04	10.9 ± 0.2
both	1.29	1.32	1.23	1.30	1.29 ± 0.04	16.3 ± 0.5

Measurements for the strong magnet:

weight	T (s)	T (s)	T (s)	T (s)	<T> (s)	<v> (m/s)
small	8.93	9.01	9.17	8.91	9.0 ± 0.1	2.33 ± 0.03
large	4.03	3.92	4.03	3.95	3.98 ± 0.06	5.28 ± 0.08
both	2.53	2.52	2.53	2.48	2.52 ± 0.03	8.3 ± 0.1

4. Discussion of the results:

- A graph between v_e and the weight should be made.
- From Eq. (2) we observe that:
 - both straight lines should intersect on the horizontal axis.
 - from the square-root of the ratio of the slopes we have immediately the ratio of the magnetic field strengths.
 - For the above measurements we find:

$$\frac{B_1}{B_2} = \sqrt{\frac{7.22}{15}} \approx 0.69 \quad \rightarrow \quad \frac{\Delta\left(\frac{B_1}{B_2}\right)}{\left(\frac{B_1}{B_2}\right)} = \frac{1}{2} \cdot \sqrt{\left(\frac{\Delta r_1}{r_1}\right)^2 + \left(\frac{\Delta r_2}{r_2}\right)^2} \approx 0.05$$

$$\frac{B_1}{B_2} = 0.69 \pm 0.03$$

Marking Breakdown

1	$M_B = c \cdot B^2 \cdot \omega$: 1
	Eq. (2)	: 1
2	Investigation of the range in which the speed is constant	: 2
3	Number of timing measurements [1,2,3,...]	: 0,1,2
	Error estimation	: 0.5
4	graph	: 0.5
	- quality	: 0.5
	- the lines intersect each other on the mass-axis	: 1
	- calculation of B_1/B_2	: 1
	- Error calculation	: 1